



Bobcat[®]

One Tough Animal.

LPG FORKLIFTS

7-Series, Pneumatic, 6.0 to 7.0 ton capacity

🌐 EMEA



ONE TOUGH ANIMAL

OUR MISSION

We empower operators to accomplish more, while working in the toughest conditions and tightest situations. When our customers have the will, we provide the way.

BOBCAT'S HISTORY

In 1958, Melroe Manufacturing Company introduced a compact front-end loader that evolved quickly into the M400, the world's first true skid steer loader. The company soon adopted what became the world-famous 'Bobcat' brand – and its success paved the way for the global compact equipment industry we know today.



YEARS OF EXPERIENCE

In 2021, Bobcat furthered its reach by acquiring Doosan Industrial Vehicle, increasing its capacity to provide customers with comprehensive business solutions. With Doosan's expertise in material handling and warehouse equipment dating back to its inaugural forklift in 1968, the company has established a global presence, with 400 dealers across 93 countries.



BOBCAT TODAY

Now, with a diversified portfolio that includes forklifts and warehouse equipment, Bobcat serves as a one-stop solution for intralogistics needs, from loading shipping containers to optimizing warehouse operations. Produced in its South Korean factory, Bobcat's material handling machines offer the precision and durability customers expect.



TOUGH, AGILE & SAFE

DESIGNED FOR PRODUCTIVITY

With high-performance engines, intuitive controls, superior operator comfort, and a host of safety features, the Bobcat G70S-7 Series is ready to boost your business's productivity while keeping expenses in check, thanks to its low cost of ownership.

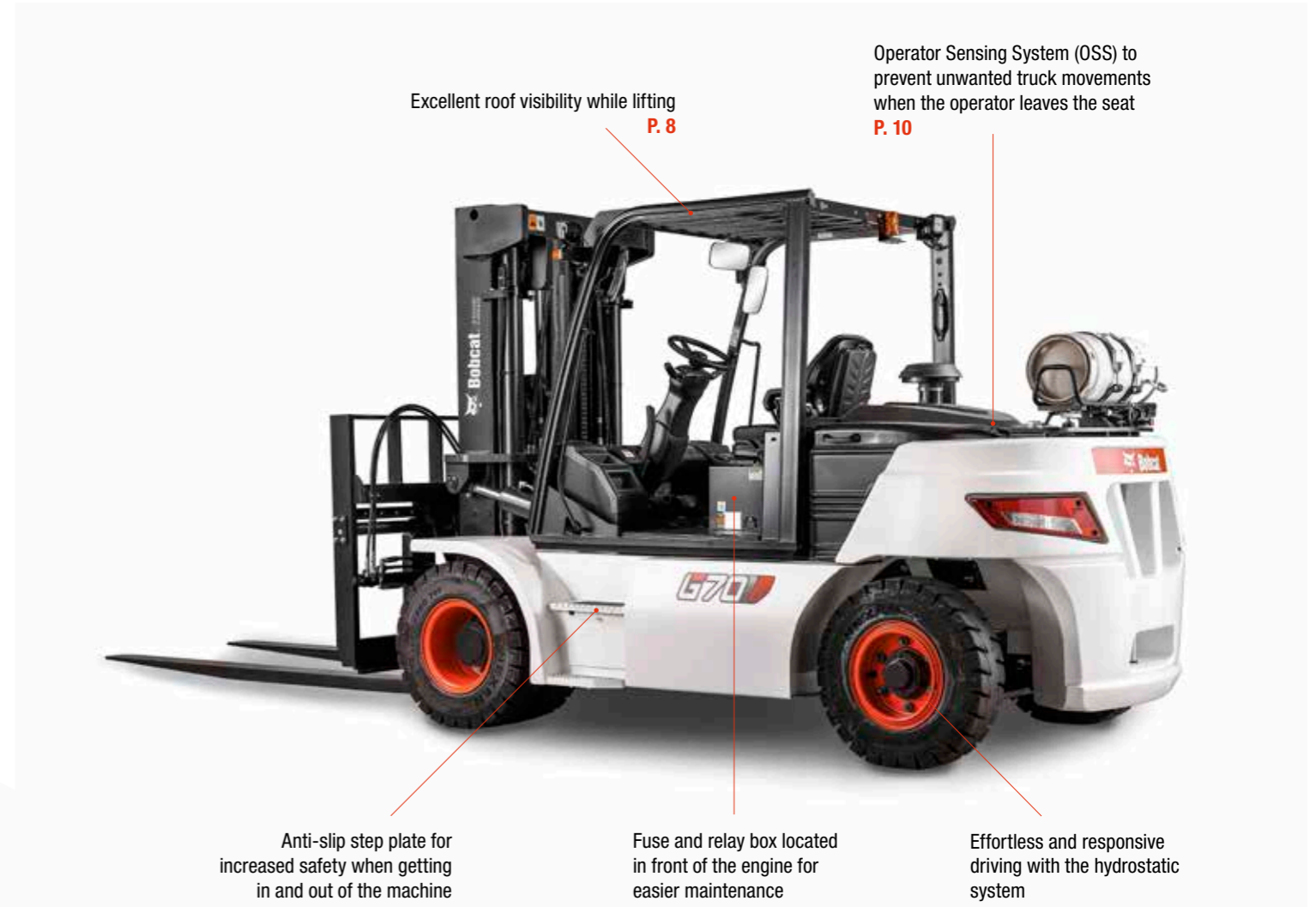

ULTIMATE PRODUCTIVITY

Achieve more every day with a high-performance, efficient engine delivering 70 kW of power and high torque at 1 800 rpm for enhanced performance in every task. P. 6-7



COMFORTABLE ALL SHIFT LONG

Enjoy the comfort of the spacious cab with plenty of leg room, deluxe suspended seat, integrated instrument panel, tiltable steering column, and more. P. 8-9



SAFETY FIRST

Protect your investment, workforce, and handled goods with excellent all-around visibility, reliable oil-cooled brakes, and a host of other safety features as standard. P. 10-11



MAXIMUM UPTIME

With longer service intervals and high-quality, genuine Bobcat parts and consumables, you can reduce the total cost of ownership and help your machine run smoother and last longer. P. 12-13



OUTSTANDING PRODUCTIVITY



▶ HYDRAULIC CONTROL

Experience the convenience of hydraulic control for lifting and tilting, providing efficient and precise handling for all your material transport needs.



▶ PRECISION IN EVERY MOVE

Achieve maximum precision in every turn with the superior hydrostatic steering system, fully floating drive axle, and oil-cooled disc brakes.



▶ EFFORTLESS DIRECTIONAL CHANGES

The well-tested powershift transmission precisely controls clutch oil pressure, ensuring smooth shifts between forward and reverse. This control helps prevent transmission damage, making the forklift stronger and longer-lasting.



▶ OIL-COOLED DISC BRAKES

Enjoy oil-cooled disc brakes for better braking and faster cycles, giving you the confidence to navigate and stop quickly. This enhancement significantly speeds up task completion and boosts overall productivity.

COMFORT & CONTROLS



▶ IMPROVED VISIBILITY

Benefit from improved operator visibility in all working positions, thanks to a wider mast window, repositioned hydraulic hoses, and a flat bar-style overhead guard.



▶ DELUXE SUSPENSION SEAT

The deluxe suspension seat is designed for operator comfort, with a larger recline, adjustable positions, and weight resistance for customizable comfort.



▶ FULL CAB

Equip your forklift with one of our cabs to conquer all weather conditions. Add options like a heater, operator fan, and power jack for all-day comfort.



▶ REAR CAMERA DISPLAY

Equip your machine with a rear-view camera that automatically feeds into the in-cab screen when driving in reverse. This ensures you always have the best view of your workplace without sacrificing your comfort.

▶ RADIO AND MP3 PLAYER



Add a radio and MP3 player in your cab to enjoy some tunes during even the longest shifts.

▶ EASY ACCESS



This forklift features a low step height, facilitating safe and effortless operator entry and exit, complemented by an easy entry grab bar and an anti-slip step plate.

▶ OPTIMUM PEDAL SYSTEM



The Optimum Pedal System (OPS), featuring a new electronic accelerator, is designed to reduce operator fatigue and deliver the best driving experience.



SAFETY IN EVERY MOVE

▶ ADVANCED PROTECTION FOR YOU AND YOUR OPERATION

Bobcat forklifts have safety embedded in their DNA. Packed with features that protect both your well-being and your investment, these machines offer peace of mind in every task, every day.

▶ OPERATOR SENSING SYSTEM

The intelligent Operator Sensing System (OSS) prevents unintended forklift movement by automatically stopping the truck's travel and mast lifting functions whenever the operator leaves the seat.



▶ MAST LOWERING INTERLOCK & TILT LOCK

The Mast Lowering Interlock & Tilt Lock system prevents unintentional lowering and tilting of the mast, protecting both the truck and the load for a more secure work environment.

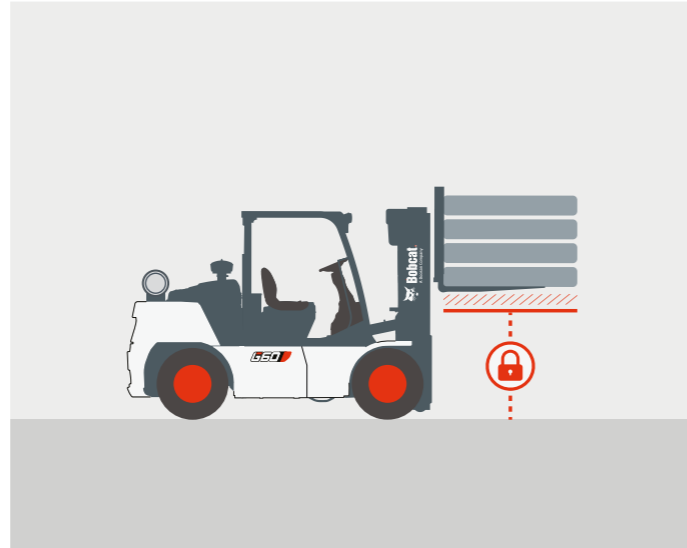

▶ BACK-UP ALARM

The back-up alarm emits a warning signal when the operator is driving in reverse, alerting those in the nearby vicinity.



▶ REAR GRAB BAR

The rear grab bar provides stability during reverse maneuvers and tight space navigation. Plus, the horn can be easily activated with the push of a button conveniently located on the bar.



▶ LOW FUEL INDICATOR

This feature minimizes interruptions to the workday by alerting the operator when the tank needs to be refilled.



▶ GROUND SPEED CONTROL

Setting a speed limit prevents the truck from going too fast. This limit can be customized for both forward and reverse directions.



▶ BRIGHTER AND SAFER

Experience a brighter, safer, and more efficient workday with our front lights, combination lamps, and an additional rear light.



▶ REAR-VIEW MIRROR

The rear-view mirror provides more visibility, preventing accidents while reversing and avoiding collisions with objects and pedestrians, ensuring a safer work environment.



BUILT TO LAST

► A HERITAGE OF RELIABILITY

The superior hydrostatic steering system is designed for high shock absorption, while the rugged frame, fully floating drive axle, and oil-cooled brakes ensure years of productivity, all day, every day.

THERE'S NO TIME FOR DOWNTIME. STAND UP TO EVERY TASK THAT COMES YOUR WAY, DAY AFTER DAY.

Robust frame and overhead guard designed to withstand the demands of industrial environments and regular heavy use

Hood door with a 60° opening for quick and easy servicing

Effortless installation, removal, and servicing of the tank facilitated by the standard swing-out-and-down LPG cradle

No mechanical connections between the steering wheel and steer axle for longer maintenance intervals

Full floating drive axle requires less downtime for maintenance, ultimately leading to improved operational efficiency

Durable cast-iron housing for precise axle alignment and extended life, and a high-tensile alloy steel shaft for improved torque transmission

An engine with fewer vibrations to ensure a longer lifespan for components

2 YEAR WARRANTY

► WARRANTY

Bobcat develops every machine to the highest standards of quality and durability. That's why our standard warranty provides 24 months or 2 000 operating hours (whichever occurs first) of coverage.



► PROTECTION PLUS EXTENDED WARRANTY

Enjoy total peace of mind with Protection Plus extended warranty. Providing the same level of protection as the standard warranty, Protection Plus also reflects different customer needs and expectations by offering a choice of durations and annual operating hours.

► EXTENSIVE DEALER NETWORK

You can rely on our network of dealers and service partners who are always ready to help you.

► BOBCAT GENUINE PARTS

Quality components delivered to our dealers guarantee that all our equipment is built to last, withstand the toughest conditions, and provide reliable performance.

MAIN SPECIFICATIONS

TECHNICAL DATA ACCORDING TO VDI 2198			
		G60S-7	G70S-7
Power type			LPG
Capacity at rated load center (kg)	Q	6 000	7 000
Load center (mm)	c	600	
Load moment constant (mm)	x	632	
Wheel base (mm)	y	2 300	
Service weight unloaded (kg)		8 745	9 425
Track width front (mm)	b10	1 584	
Track width rear (mm)	b11	1 550	
Tilt mast / fork carriage forward / backward (°)	α / β	15 / 10	
Height, mast lowered (mm)	h1	2 495 – 4 095	
Free lift (mm)	h2	205 – 2 540	
Lift height (mm)	h3	3 000 – 7 275	
Height, mast extended (mm)	h4	4 275 – 7 070	4 275 – 7 275
Height overhead guard (mm)	h6	2 455	
Seat height (mm)	h7	1 455	
Length to fork face (mm)	l2	3 618	3 697
Overall width (mm)	b1	2 108	
Forks (thickness × width × length) (mm)	s, e, l	60 × 180 × 1 200	
Ground clearance, loaded, at the lowest point (mm)	m1	176	
Ground clearance, loaded, center of wheel base (mm)	m2	205	
Aisle width for pallets 1 000 × 1 200, crossways (mm)	Ast	5 212	5 262
Aisle width for pallets 800 × 1 200, lengthways (mm)	Ast	5 012	5 062
External turning radius (mm)	Wa	3 380	3 430
Travel speed, loaded / unloaded (km/h)		22.6 / 23.7	22.5 / 23.4
Lift speed, loaded / unloaded (mm/s)		380 / 410	
Lowering speed, loaded / unloaded (mm/s)		490 / 460	
Max. drawbar pull, loaded (kg)		4 262	4 236
Max. gradeability, loaded (%)		30	26.5
Service brake		foot / hyd.	
Manufacturer / type		PSI 4.3 I	
Rated speed (kW)		70	
Torque at 1 / min (N•m) @ rpm		283.9 @ 1 800	
Cylinders / displacement (cc)		6 / 4 294	

Specification values in this sheet have been rounded. Performance may vary depending on operating conditions. Products and specifications are subject to improvement and change without prior notice.

(1) Mast dimensions refer to a range from the lowest to the highest available mast with load backrest.

Note: Load capacities are based on the standard chassis without a side shifter.

STANDARD EQUIPMENT & OPTIONS

STANDARD EQUIPMENT & OPTIONS	
PRODUCTIVITY	
Power steering	✓
High powered, fuel efficient engine	✓
Autoshift controller	✓
Electric controlled LPG engine	✓
Pedal location (accelerator, brake and inching)	✓
Inching pedal	✓
Swing out and down LPG cradle – single LPG tank	✓
Swing out and down LPG cradle – dual LPG tank	•
Quick disconnect hose couplings	•
SAFETY	
Parking brake	✓
Overhead guard	✓
2 front LED lights	✓
Operating Sensing System (OSS)	✓
Neutral starting position	✓
Direction Lever Function	✓
Mast lowering and tilting interlock	✓
Engine Shutdown	✓
Anti-clinching type orange seat belt	✓
Autoshift controller	✓
Anti-slip step plate	✓
Combination lamps (LED)	•
Back-up alarm	•
Panoramic mirror	•
Seat belt interlock	•
Ground speed control	•
Rear-view camera	•
Strobe light (amber / red)	•
Safety light	•
Back-up buzzer	•
Low fuel indicator with warning lamp	•
Rear-view mirror	•

STANDARD EQUIPMENT & OPTIONS	
ERGONOMICS	
Excellent visibility	✓
Easy entry grab bar	✓
Anti-slip step plate	✓
Adjustable steering column	✓
Integrated instrument panel	✓
Full cab with heater or air conditioner – manually tiltable	•
Steering wheel knob	•
Premium suspension seat	•
Radio and MP3 for full cab	•
Tool kit	•
Cigar and power jack	•
Operator fan	•
RELIABILITY	
Oil-cooled disc brakes (ODB)	✓
Full floating drive axle	✓
Use waterproof connectors	✓
Robust frames and masts	✓
Pre-cleaner	•
SERVICEABILITY	
Dual element air cleaner	✓
Integrated electric components (relays and fuses)	✓
Easy to access to service components through trap door	✓
Wide hood open range	✓
Easyview (software to adjust parameters)	✓
Service notification	✓

*This list is based on factory data. Standard or optional can vary for specific countries.

• = option
 ✓ = standard
 – = not available

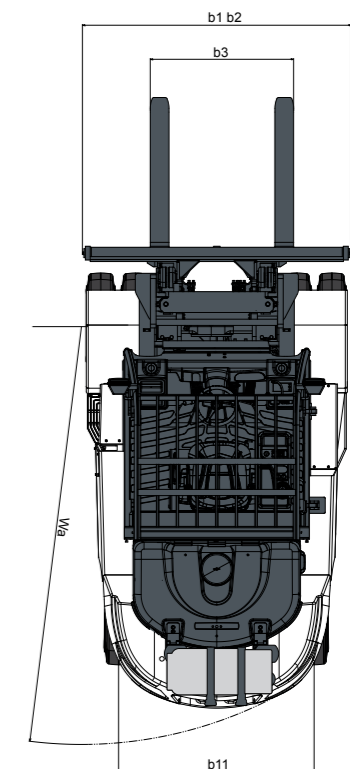
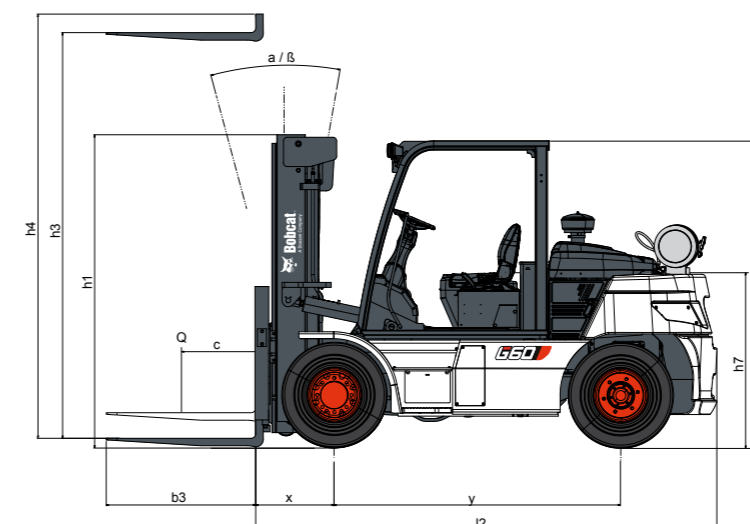

FINANCING OPTIONS

24, 36, OR 48 MONTH FINANCING*

Take advantage of 24, 36 or 48 month financing programs starting from **0% interest** and improve your cashflow.

Ask your dealer for the financing offers available.

340 MACHINES / 150 ATTACHMENT FAMILIES / 1 TOUGH ANIMAL



**SKID-STEER
LOADERS**



**COMPACT TRACK
LOADERS**

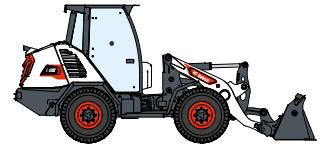

**COMPACT WHEEL
LOADERS**



FORKLIFTS

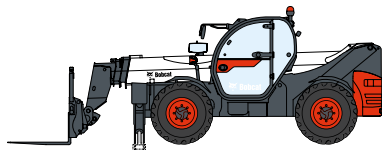

TELEHANDLERS

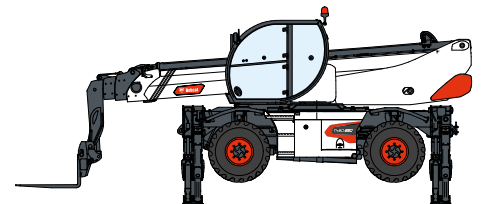

ROTARY TELEHANDLERS



**LIGHT COMPACTION
EQUIPMENT**



**COMPACT
EXCAVATORS**



**COMPACT
TRACTORS**

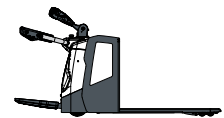

**WAREHOUSE
EQUIPMENT**



**MINI TRACK
LOADER**



MOWERS



**PORTABLE
POWER**

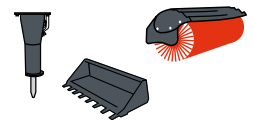

ATTACHMENTS

DOOSAN

Bobcat is a Doosan Company. Doosan is a global leader in construction equipment, power & water solutions, engines, and engineering proudly serving customers and communities for more than a century. | Bobcat and the Bobcat logo are registered trademarks of Bobcat Company in the United States and various other countries. ©2024 Bobcat Company. All Rights Reserved.

www.bobcat.com

©2024 BOBCAT B4502810-EN (04-24)



Bobcat®

*Financing options may vary by country and dealer. Always ask your dealer about currently available financing options. Terms and conditions may apply.

Doosan Bobcat EMEA, U Kodelky 1810, 263 12 Dobříš, Czech Republic